

NEWWORLD

Vision

55HLG

55cm High Level Gas Freestanding Cooker
(for Natural Gas models only)

user • installation • instructions

If you smell gas:

Do not try to light any appliance. Do not touch any electrical switch.

Call the Gas Emergency Helpline at TRANSCO on: **0800 111999**

In the Republic of Ireland, call the Bord Gáis emergency line on
1850 205050 or contact your local gas supplier.

The Gas Consumer Council (GCC) is an independent organisation which protects the interests of gas users. If you need advice, you will find the telephone number in your local telephone directory under Gas.

The appliance must be installed (and serviced) by a Corgi registered approved installer or a person competent to ensure that the installation is in accordance with "The Gas Safety (Installation & Use) Regulations 1994", & the "The Gas Safety (Installation & Use) (Amendment) Regulations 1996". Failure to comply with these Regulations is a criminal offence.



Contents

User's Section	2 - 14
Introduction	2
Storage compartment	4
Be Safe - Not Sorry.	5
Using the Hob	6
Using the Grill	7
Using the Oven	8
Oven ignition	8
Oven furniture	9
Slow cooking.	9
Baking guide	10
Traditional fruit cakes	11
Roasting turkey.	11
Roasting guide.	12
Cleaning.	13
Installation Instructions	15 - 20
Regulations and Standards.	15
Ventilation Requirements	15
Clearances & dimensions.	16
Assemble grill	17
Stability device.	18
Levelling	18
Connect to Electricity supply	19
Connect to the Gas supply.	20
Commissioning.	20
Technical Data	21
New World Customer Care	24

Please keep this handbook for future reference, or for anyone else who may use the appliance.

Introduction

Thank you for choosing a New World appliance

We hope that the following information will help you to familiarise yourself with the features of the appliance, and to use it successfully and safely.

Our policy is one of constant development & improvement. Strict accuracy of illustrations and specifications is not guaranteed. Modification to design and materials may be necessary subsequent to publication.

This appliance must be installed in accordance with the regulations in force, and only in a well ventilated space. Read the instructions before installing or using this appliance.

Your new appliance is designed to be installed flush to base units. Certain features, such as oven lights, are only available on some models.

Your 1st Year Guarantee

To fulfil the conditions of your guarantee, this appliance must be correctly installed and operated, in accordance with these instructions, and only be used for normal domestic purposes. Please note that the guarantee, and Service availability, only apply to the UK and Republic of Ireland.

Moving the cooker

Do not attempt to move the cooker by pulling on the doors or handles. Open the door and grasp the frame of the cooker, taking care that the door does not shut on your fingers.

Take care to avoid damage to soft or uneven floor coverings when moving the appliance. Some cushioned vinyl floor coverings may not be designed to withstand sliding appliances without marking or damage.

Stability bracket

If the cooker is to be fitted with a flexible inlet connection, a stability bracket should also be fitted to engage in the back of the cooker. Make sure this is re-engaged whenever you move the cooker for cleaning.

Before using the appliance for the first time, remove any protective polythene film and wash the oven shelves and furniture in hot soapy water, to remove their protective coating of oil. Even so, when you first turn on the oven or grill you may notice a smell and some smoke.

Introduction

Glass door panels

To meet the relevant Standards of Domestic cooking appliances, all the glass panels on this appliance are toughened to meet the fragmentation requirements of BS3193. This ensures that, in the unlikely event that a panel breaks, it does so into small fragments to minimise the risk of injury.

Please take care when handling, using or cleaning all glass panels as any damage to the surfaces or edges may result in the glass breaking without warning or apparent cause at a later date. Should any glass panel be damaged, we strongly recommend that it is replaced immediately.

Gas & Electrical connection

Please refer to installation instructions for the Gas & Electrical Safety Regulations and the Ventilation Requirements.

In your own interest, and that of safety, it is the law that all gas appliances be installed by competent persons. Corgi registered installers undertake to work to satisfactory standards.

Disconnection of gas and electric appliances should always be carried out by competent persons.

Warning: This appliance must be earthed.

Environmental Protection

Stoves Limited is committed to protecting the environment and operates an Environmental Management System which complies with BS EN ISO 14001:1996.

Disposal of packaging

- All our packaging materials are recyclable and environmentally friendly.
- Please help us to protect our environment by disposing of all packaging in an environmentally friendly manner.
- Please contact your local authority for the nearest recycling centre.

Caution: Packaging materials can pose a risk of suffocation - keep away from children.

Introduction

Ignition

The appliance has mains powered spark ignition.

If the ignition fails:

- Check there is a spark when the ignition button is depressed. If there is no spark, check that the electricity supply is switched on at the socket.
- Check that the gas supply is switched on.
- Try another appliance in the socket, if that works, replace the 3 amp fuse in the cooker plug.

Ventilation

The use of a gas cooking appliance results in the production of heat and moisture in the room in which it is installed. Ensure that the kitchen is well ventilated: keep natural ventilation holes open or install a mechanical ventilation device (mechanical extractor hood). Prolonged intensive use of the appliance may call for additional ventilation, for example, opening of a window, or more effective ventilation, for example increasing the level of mechanical ventilation where present.

Storage compartment

The storage compartment should only be used to store oven furniture.

Baking trays and roasting tins may be stored in the compartment.

Do not store items with plastic or wooden handles in the compartment, as they may be damaged by heat from the oven.

Do not store flammable liquids, even when cold, in the storage compartment, as they may catch fire. Do not store flammable items - ie; chip pans.

Do not store food in the storage compartment. Do not use the compartment as a food warming facility.

Be Safe - Not Sorry

When you are cooking, keep children away from the vicinity of the appliance.

This product is designed as a domestic cooking appliance for the preparation and cooking of domestic food products, and should not be used for any other purpose.

- Remove all packaging, protective films and oils from the appliance before using for the first time.
- Make sure you read and understand the instructions before using the appliance.
- Keep electrical leads short so they do not drape over the appliance or the edge of the worktop.
- Keep all flammable materials (such as curtains, furnishings & clothing) away from the appliance.
- Parts of the appliance may be hot during or immediately after use. Allow sufficient time for the appliance to cool after switching off.
- Never use the appliance for heating a room.
- Do not drape tea towels over the flue vents or doors as this creates a fire hazard.
- When opening the appliance door, take care to avoid skin contact with any steam which may escape from the cooking.
- Do not use aluminium foil to cover the grill pan, or put items wrapped in foil under the grill as this creates a fire hazard.
- Do not use the oven with the door inner glass panel removed.
- Use oven gloves when removing hot food / dishes from the oven or grill. The oven / grill and utensils will be very hot when in use.
- Do not use foil on oven shelves or allow it to block the oven flue, as this creates a fire hazard, and prevent heat circulation.
- When cooking heavy items - eg; turkeys - do not pull the oven shelf out with the item still on the shelf.
- When you have finished cooking check that all controls are in the off position.
- **All installation, servicing and maintenance** work should be carried out by a competent person who will comply with current Regulations, Standards and Requirements.
- As with all gas appliances, it is recommended that your appliance is serviced regularly.

Using the Hob

Ignition

Push in and turn the selected control knob anticlockwise to the 'full on' position and press the ignition switch, or hold a lighted match or taper to the burner, until the burner lights. Turn the control knob to the required setting.

Adjust the burner flame so that it does not extend over the pan base.

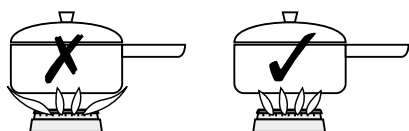

To turn off, push in the control knob and turn clockwise until the dot on the control knob is below the dot on the fascia panel.

To simmer

The simmer position is marked by the SMALL FLAME symbol.

Once lit turn the selected control knob anticlockwise past the LARGE FLAME symbol (FULL ON) to the SMALL FLAME symbol.

You may hear a slight popping noise when the hob burners are operating and this is quite normal, but if anything about the cooker appears unusual, such as change in flame appearance, or the operation of controls - seek expert advice.

Pans

For optimum safety and performance, we recommend the use of flat bottomed pans with a base diameter of minimum 100mm (4") and maximum 250mm (10").

Do not use double pans, rim based pans, old misshapen pans or any pan which is unstable when placed on a flat surface.

Position pans over the centre of the burners, resting on the pan supports. If positioned off centre, smaller pans may be unstable.

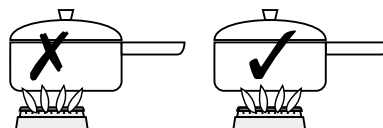

When cooking with fat or oil, never leave unattended.

Turn pan handles to a safe position, so they are out of reach of children, not overhanging the appliance, and cannot be caught accidentally.

Commercial simmering aids should not be used as they create excessive temperatures that can damage the surface and may cause a hazard.

Pan supports

Always make sure the pan supports are replaced correctly, and located in the hob spillage well.

Using the Grill

Caution: Accessible parts may be hot when the grill is used. Young children should be kept away.

Make sure that the grill pan is first pushed back to the rear stop position and engage onto the grill pan runners before pulling forward to the front stop position.

Ignition

Push in and turn the grill control knob anticlockwise to the 'FULL ON' position and press the IGNITION SWITCH, or hold a lighted match or taper to the burner, until the burner lights.

Turn the control knob to the required setting.

When slower cooking is required the grill can be turned down anti-clockwise to a slightly reduced setting, past the large flame symbol (full on), to the small flame symbol. This can be used in conjunction with use of the different grilling positions (see section on grilling). Only use the grill burner between the large and small flame symbol.

To turn off, push in the grill control knob and turn clockwise to the "●" off position.

Preheating

Always preheat the grill for about 3 minutes, for best cooked results.

Grilling

There are three different grilling positions, as the grill trivet, which is in the grill pan, may be inverted to give a high or low position or the trivet may be removed.

1. The HIGH trivet position is suitable for toasting bread.
2. The LOW trivet position is suitable for grilling all types of meat & fish.
3. With the grill trivet removed the food is placed directly on the base of the grill pan - eg; when cooking whole fish or browning dishes such as cauliflower cheese.

Using the Oven

Caution: Accessible parts may be hot when the appliance is in use, young children should be kept away.

Ignition

Push in and turn the selected control knob anticlockwise to the 'full on' position (gas mark 9) and press the IGNITION SWITCH (if fitted), or hold a lighted match or taper to the oven burner, until the burner lights. Turn the control knob to the required setting.

If after 15 seconds, the burner has not lit, switch off the oven and leave the compartment door open. Wait at least one minute before a further attempt to ignite the burner.

Do not hold the control knob in for more than 15 seconds.

To turn off push in the control knob and turn clockwise until the dot on the control knob is below the dot on the fascia panel.

In the event of the burner flames being accidentally extinguished, turn off the burner control and do not attempt to re-ignite the burner for at least one minute.

If you find that over a period of time, the oven becomes hotter when used at a particular gas mark, the thermostat may need to be replaced.

Preheating

The oven must be preheated for 15 minutes when cooking frozen or chilled foods, and we recommend preheating for yeast mixtures, batters, soufflés, and whisked sponges.

If you are not preheating the oven, the cooking times in the following guides may need to be extended, as they are based on a preheated oven.

Zones of heat

The temperature at the centre of the oven corresponds with the selected gas mark and is slightly higher towards the top of the oven and slightly lower towards the oven base.

These zones of heat can be useful as different dishes requiring different temperatures can be cooked at the same time, when more than one shelf is used.

The temperature at the oven base is suitable for cooking baked vegetables, baked fruit, milk pudding etc, and for warming bread rolls, soup, coffee, or ovenproof plates and dishes.

Notes:

As part of the cooking process, hot air is expelled through a vent at the top of the oven. When opening the oven door, care should be taken to avoid any possible contact with potentially hot air, since this may cause discomfort to people with sensitive skin. We recommend that you hold the underneath of the oven door handle.

Using the Oven

Oven furniture

Baking tray and roasting tins

For best cooked results and even browning, the maximum size baking trays and roasting tins that should be used are as follows;

Baking tray 350mm x 280mm

This size of baking tray will hold up to 20 small cakes.

Roasting tin 370mm x 320mm

We recommend that you use good quality cookware. Poor quality trays and tins may warp when heated, leading to uneven baking results.

Shelves & positions

The oven shelf must be positioned with the upstand at the rear of the oven and facing upwards.

To allow for heat circulation, position baking trays and roasting tins on the middle of the shelves, and leave one clear shelf position between shelves when cooking with more than one shelf.

When cooking 2 trays or items, remove the top item when it is cooked and raise the lower item to the higher shelf to finish cooking, or where additional browning of the bases is required - eg; pies and pastries - interchange part way through cooking.

If you prefer darker cooked results, cook on a higher shelf, for paler results use a lower shelf.

Slow cooking

Make sure that frozen foods are thoroughly THAWED before cooking.

Do not slow cook joints of meat or poultry weighing more than 2¼ kg / 4½lb.

Always use the top half of the oven for slow cooking.

For roasting joints of meat or poultry, and for pot roasts preheat the oven to gas mark 6 and cook for 30 minutes, then adjust the oven control to the 'S' slow setting for the remainder of the cooking time.

Slow cooking times will be about three times as long as conventional cooking times.

Baking guide

Please note that the times and temperatures stated in the baking guide are only intended for reference only - refer to your recipe.

Using the Oven

Baking guide Dish	Recommended gas mark	Shelf position	Approximate cooking time
Scones Meringues	7 "S" slow setting	top to middle middle to bottom	8 - 15 mins 3 - 4 hours
Cakes Small cakes Whisked sponge Swiss roll Victoria sandwich (2 x 180mm / 7") Genoese sponge Madeira (180mm/7") Gingerbread Very rich fruit cake (205mm / 8") Semi rich fruit cake (205mm /8")	5 5 6 4 4 3 2 1 or 2 2 or 3	middle to top middle to top middle to top middle to top middle middle to bottom middle to bottom middle to bottom middle to bottom	15 - 25 mins 20 - 30 mins 8 - 15 mins 20 - 35 mins 20 - 30 mins 1¼ - 1½ hours 1 - 1½ hours 3½ - 4 hours 2½ - 3 hours
Pastry Rough puff Flaky / Puff Shortcrust Flan Choux	7 7 6 6 6	middle to top middle to top middle to top middle to top middle to top	15 - 45 mins 15 - 45 mins 15 - 45 mins 15 - 45 mins 20 - 45 mins
Biscuits Shortbread fingers Nut brownies Flapjacks Ginger nuts	3 3 4 5	middle to top middle to bottom middle to top middle to top	20 - 30 mins 12 - 18 mins 20 - 40 mins 7 - 12 mins
Puddings Rice pudding Baked custard Bread and butter Hot soufflé Fruit crumble	2 2 or 3 3 4 5	middle to bottom middle to bottom middle middle to top middle to top	2 - 2½ hours 1 - 1¼ hours 1 - 1¼ hours 40 - 50 mins 30 50 mins
Bread (2 x 500g) Bread (1 x 1kg)	7 7	middle to top middle to top	20 - 40 mins 30 - 45 mins

Using the Oven

Traditional fruit cakes

It should be remembered that ovens can vary over time, therefore cooking times can vary, making it difficult to be precise when baking fruit cakes.

It is necessary therefore, to test the cake before removal from the oven. Use a fine warmed skewer inserted into the centre of the cake. If the skewer comes out clean, then the cake is cooked.

- Do not attempt to make Christmas cakes larger than the oven can cope with, you should allow at least 25mm (1 inch) space between the oven walls and the tin.
- Always follow the temperatures recommended in the recipe.
- To protect a very rich fruit cake during cooking, tie 2 layers of brown paper around the tin.
- We recommend that the cake tin is not stood on layers of brown paper, as this can hinder effective circulation of air.
- Do not use soft tub margarine for rich fruit cakes, unless specified in the recipe.
- Always use the correct size and shape of tin for the recipe quantities.

Roast turkey

Roasting turkey involves cooking two different types of meat - the delicate light breast meat, which must not be allowed to dry out, and the darker leg meat, which takes longer to cook.

The turkey must be roasted long enough for the legs to cook, so frequent basting is necessary. The breast meat can be covered once browned.

- Always make sure that the turkey is completely thawed and that the giblets are removed before cooking.
- Turkey should be roasted at gas mark 4 for 20 minutes per 1lb, plus 20 minutes, unless packaging advises otherwise.
- The turkey can be open roasted, breast side down, for half of the cook time, and then turned over for the remainder of the cooking time.
- If the turkey is stuffed, add 5 minutes per 1lb to the cooking time.
- If roasting turkey covered with foil, add 5 minutes per 1lb to the cooking time.

To test if the turkey is cooked, push a fine skewer into the thickest part of the thigh. If the juices run clear, the turkey is cooked. If the juices are still pink, the turkey will need longer cooking.

Using the Oven

Roasting guide

The times given in the roasting guide are only approximate, because the size and age of the bird will influence cooking times as will the shape of a joint and the proportion of bone.

Frozen meat should be thoroughly thawed before cooking. For large joints it is advisable to thaw overnight.

Frozen poultry should be thoroughly thawed before cooking. The time required depends on the size of the bird - eg; a large turkey may take up to 48 hours to thaw.

Use of a trivet with a roasting tin will reduce fat splashing and will help to keep the oven interior clean. Alternatively, to help reduce fat splashing, potatoes or other vegetables can be roasted around the meat / poultry.

Notes:

- When cooking stuffed meat or poultry, calculate the cooking time from the total weight of the meat plus the stuffing.
- For joints cooked in foil or covered roasters, and for lidded casseroles, add 5 minutes per 450g (1lb) to the calculated cooking time.
- Smaller joints weighing less than 1.25kg (2½lb) may require 5 minutes per 450g (1lb) extra cooking time.
- Position the oven shelf so that the meat or poultry will be in the centre of the oven.
- It is recommended that the appliance is cleaned after open roasting.

Cook in oven at Gas Mark 5		Approximate Cooking Time (preheated oven)
Beef	Rare	20 minutes per 450g (1lb), plus 20 minutes
	Medium	25 minutes per 450g (1lb), plus 20 minutes
	Well done	30 minutes per 450g (1lb), plus 30 minutes
Lamb	Medium	25 minutes per 450g (1lb), plus 25 minutes
	Well done	30 minutes per 450g (1lb), plus 30 minutes
Pork		35 minutes per 450g (1lb), plus 35 minutes
Poultry		20 minutes per 450g (1lb), plus 20 minutes

Cleaning

Caution: Any cleaning agent used incorrectly may damage the appliance.

Always let the cooker cool before cleaning.

Some cooking operations generate considerable amount of grease, this combined with spillage can become a hazard if allowed to accumulate on the cooker through lack of cleaning. In extreme cases this may amount to misuse of the appliance and could invalidate your guarantee.

It is recommended that the appliance is cleaned after open roasting.

Do not use caustic pastes, abrasive cleaning powders, coarse wire wool or any hard implements, as they will damage the surfaces.

All parts of the appliance can be safely cleaned with a cloth wrung out in hot soapy water.

Burner caps and heads

Important: Allow burners to cool before cleaning.

Caution: Hotplate burners can be damaged by soaking, automatic dishwashers (or dishwasher powders / liquids), caustic pastes, hard implements, coarse wire wool, and abrasive cleaning pastes.

Clean with a moist soapy pad - eg; "Brillo".

For the burners to work safely, the slots in the burner head where the flames burn need to be kept clear of deposit. Clean with a nylon brush, rinse, and dry thoroughly.

Important: The burner caps and heads must be repositioned correctly so that they sit squarely onto the hob as shown.

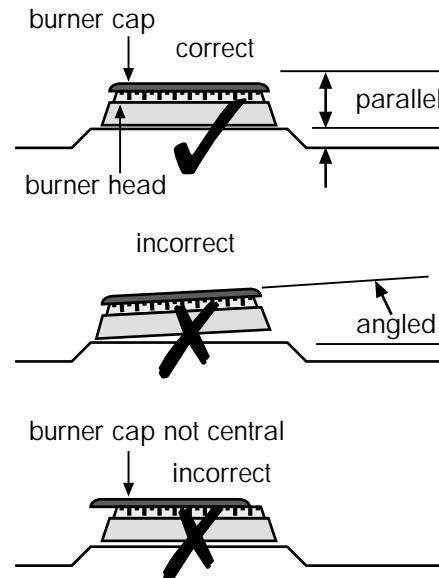

Cleaning

Vitreous Enamel parts

SPLASHPLATE, GRILL PAN, GRILL CANOPY, HOB TOP & PAN SUPPORTS, OVEN COMPARTMENT

Use a mild cream cleaner - eg; "Cif".

Stubborn marks may be removed with a moistened "Brillo" pad.

The pan supports and grill pan may be cleaned in a dishwasher, or with a nylon brush in hot soapy water.

Painted, plastic & metal finish parts

OVEN DOOR FRAME & HANDLE, GRILL PAN HANDLE, FACIA PANEL & CONTROL KNOBS

Only use a clean cloth wrung out in hot soapy water.

Glass parts

GLASS DOOR PANELS

Do not use abrasives or polishes as they will scratch and damage the glass.

Use a mild cream cleaner - eg; "Cif". Rinse away excess cleaner and dry with a soft cloth.

The oven door inner glass panel can be removed for cleaning by grasping the top and bottom edges and sliding out.

Chrome plated parts

OVEN SHELF & SHELF RUNNERS, GRILL PAN RUNNERS, GRILL PAN TRIVET

Use a moist soap pad, eg; "Brillo".

Note: Oven shelf runners can be removed for cleaning. Grasp the runners and slide out of the hanging holes as shown.

Note: These items may also be cleaned in a dishwasher.

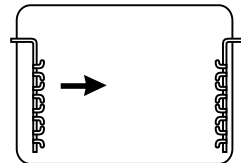

Installation Instructions

Before you start: Please read the instructions. Planning your installation will save you time and effort.

Prior to installation, ensure that the local distribution conditions (nature of the gas and gas pressure) and the adjustment of the appliance are compatible. The adjustment conditions are stated on the data badge.

This appliance is not connected to a combustion evacuation device. It shall be installed and connected in accordance with current installation regulation. Particular attention shall be given to the relevant requirements regarding ventilation.

In your own interest and that of safety, it is the law that all gas appliances be installed and serviced by competent persons. CORGI registered installers undertake to work to satisfactory standards.

Where regulations or standards have been revised since this handbook was printed, always use the latest edition.

In the UK the regulations and standards are as follows:

1. Gas Safety Regulations 1996 (Installation and Use).
2. Building Regulations - Issued by the Department of the Environment.
3. Building Standards (Scotland) (Consolidated) - Issued by the Scottish Development Department.
4. The current I.E.E. Wiring Regulations.
5. Electricity at Work Regulations 1989.
6. BS 6172 Installation of Domestic Gas cooking Appliances
7. Installation & Servicing Instructions for this appliance.

For installation in countries other than the UK, the appliance must be connected in accordance with all local gas and electrical regulations.

In the Republic of Ireland, Installers should refer to IS813 Domestic Gas Installations.

Ventilation Requirements

The room containing the appliance should have an air supply in accordance with BS 5440: Part 2: 1989:

- All rooms require an openable window, or equivalent, and some rooms will require a permanent vent as well.
- For room volumes up to 5m³ an air vent of 100cm² is required.
- If the room has a door that opens directly to the outside, or the room exceeds 10m³, NO AIR VENT is required.
- For room volumes between 5m³ and 10m³ an air vent of 50cm² is required.
- If there are other fuel burning appliances in the same room, BS 5440: Part 2: 1989 should be consulted to determine the air vent requirements.
- This appliance must not be installed in a bed sitting room of less than 20m³ or in a bathroom or shower room.

Windows and permanent vents should therefore not be blocked or removed without first consulting a CORGI gas installer.

In the Republic of Ireland, refer to relevant Irish Standards for correct ventilation requirements.

Failure to install appliances correctly is dangerous and could lead to prosecution.

Installation Instructions

Whilst every care is taken to eliminate burrs and raw edges from this appliance, please take care when handling - we recommend the use of protective gloves during installation

Moving the cooker

Please note that the weight of this appliance is approximately **47kg** (unpacked).

Take care if the appliance needs to be lifted during installation - always use an appropriate method of lifting.

Do not attempt to move the cooker by pulling on the doors or handles. Open the door and grasp the frame of the cooker, taking care that the door does not shut on your fingers.

Take care to avoid damage to soft or uneven floor coverings when moving the appliance. Some cushioned vinyl floor coverings may not be designed to withstand sliding appliances without marking or damage.

Clearances & dimensions

Clearances

No shelf or overhang or cooker hood should be closer than a minimum of 460 mm, but check with cooker hood manufacturer's recommendations.

The cooker must have a side clearance above hob level of 90mm.

This cooker may be fitted flush to base units. However, for models with side opening doors, we recommend a side clearance of 60mm between the cooker and any side wall to allow the door to be opened fully.

Cooker dimensions

All sizes are nominal, and some variation is to be expected. The 'depth' of the cooker, as given below, is to the front of the door and excluding knobs and handles.

Width is 550mm.

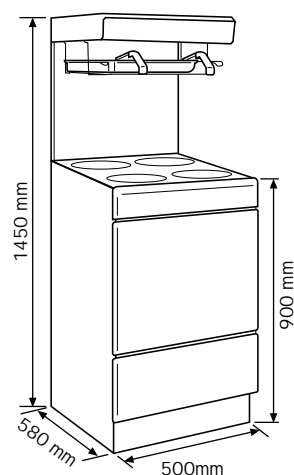

Installation Instructions

Assemble grill

Fitting the grill canopy

Fixing screws and washers that are not loosely assembled in position are in the plastic bag in the oven pack.

1. There are 4 screws in the back of the cooker which will secure the splashplate (through the uprights) onto the back of the cooker.
2. Loosen the 2 lower screws (2 either side) in the back of the cooker, until some of the thread is showing.
3. Remove the 2 higher screws and keep to hand.

Pick up the splashplate and grill canopy and lower it onto the back of the cooker so the slots in the uprights locate over the loosened screws.

4. Replace the 4 screws into the slotted holes and tighten each screw in turn.
5. Connect the grill pipe from the tap rail to the straight hexagon connector.

Make sure the connections are gas sound.

Grill electrode lead

Feed the grill electrode lead through the hole at the top left-hand corner of the splashplate (viewed from rear) and connect it to the grill electrode. *Do not* feed the wire through the grill shelf wire slots. Feed any slack lead to the back of the cooker and clip with the plastic twist clip provided.

Fit the grill shelf

Note: For ease of assembly, slacken the 4 screws holding the canopy to the splashplate, before offering up the grill shelf.

1. Remove the four grill securing screws M4 x 10mm which are loosely assembled in position on the grill canopy.
2. Offer the grill shelf up to the underside of the grill canopy with the rubber end caps right up against the splashplate and use the four M4 x 10mm screws to secure into place.

Fit the grill pan

Place the grill pan onto the grill pan runners and push to the back stop position, raise the front edge of the grill pan to engage it onto the grill pan runners. The grill pan can now be pulled forwards to fit the front stop position.

Fit the spacers

From the rear of the grill canopy, fit the plastic spacers into the elongated hexagonal holes as shown.

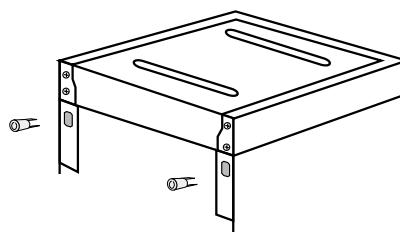

Installation Instructions

Stability bracket

If the cooker is fitted with a flexible connection, a stability bracket should be fitted to engage in the back of the cooker. A stability bracket can be bought from your local supplier.

A stability bracket can be fitted as follows:

1. Place the cooker in position and draw a PENCIL LINE level with the front edge.
2. Mark the centre of the cooker to give the CENTRE LINE for the bracket.
3. Remove the cooker and mark off 450mm from the PENCIL LINE to locate the front edge of the lower bracket.

4. Fix the bracket to the floor.

Measure from FLOOR LEVEL to ENGAGEMENT EDGE in the back of the cooker and add 3mm.

5. Assemble the underside of the top part of the bracket to this height.

Levelling

Place a spirit level on a baking sheet onto an oven shelf.

The cooker is fitted with levelling feet and locknuts at the FRONT, and levelling feet only at the rear.

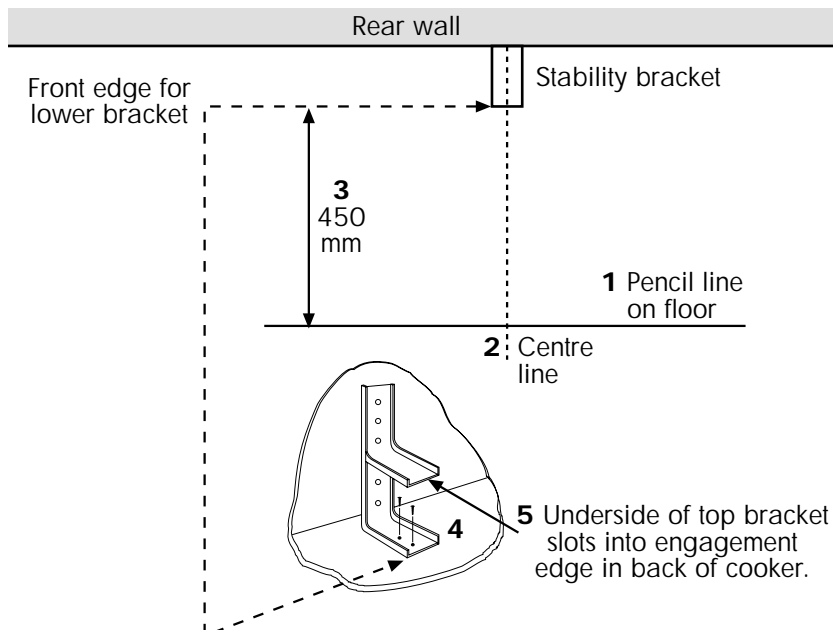

Installation Instructions

Connect to the electricity supply

Warning: This appliance must be earthed.

The flexible mains lead is supplied connected to a BS 1363 fused plug, having a fuse of **3 amp** capacity.

If this plug does not fit the socket in your home, it should be replaced with a suitable plug as outlined below.

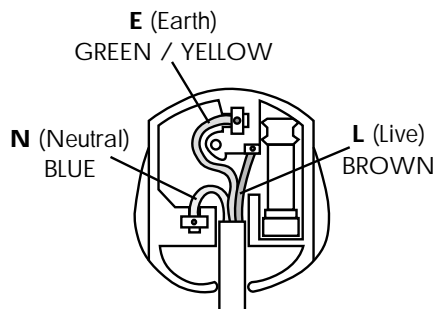

Use a **3 amp** fuse in a 13 amp plug.

The wires in the mains lead are coloured in accordance with the following code:

Green and yellow = Earth,

Blue = Neutral,

Brown = Live.

As the colours of the wires in the mains lead for the appliance may not correspond with the coloured markings identifying the terminals in your plug, proceed as follows:

1. The wire which is coloured green and yellow must be connected to the terminal marked **E**  (Earth) or coloured Green.
2. The wire which is coloured blue must be connected to the terminal marked **N** (Neutral), or coloured Black.
3. The wire which is coloured brown must be connected to the terminal marked **L** (Live), or coloured Red.

The plug and socket must be accessible after installation.

Should the mains lead of the appliance ever require replacing, we recommend that this is carried out by a qualified electrician who will replace it with a lead of the same size and temperature rating.

Important: - ensure that you route all mains and electrical cables and flexible tubing well clear of any adjacent heat source.

Installation Instructions

Connect to the gas supply

The inlet to the cooker is ½" BSP internal situated at the rear right corner.

Use a 900mm - 1125mm length of flexible connector.

Ensure that all pipe work is of the correct rating for both size and temperature.

Flexible connections should comply with BS 669. Parts of the appliance likely to come into contact with a flexible connector have a temperature rise of less than 70°C.

After installation, make sure all connections are gas sound.

Commissioning

Burner aeration

All burners have fixed aeration and no adjustment is possible.

Pressure setting

G20 Natural Gas @ 20 mbar

Pressure test point

Use the oven injector

Grill - Turn the control knob to the FULL ON position, wait a second before pressing the ignition switch or holding a lighted match or taper to the burner.

Hob - Turn the control knob to the FULL ON position, wait a second before pressing the ignition switch or holding a lighted match or taper to the burner.

Oven - Open the oven door. Turn the control to the FULL ON position and press the ignition switch, or holding a lighted match or taper to the burner. The burner operates at a low rate for up to 60 seconds until the flame supervision device opens and full gas rate is obtained.

Before leaving the installation

1. Place all the loose parts of the cooker into position.
2. Show the customer how to operate the cooker and give them this handbook. Thank you.

Technical Data

Data badge - Inside storage compartment

Type of gas

This cooker must only be used with either Natural Gas only, as specified on the appliance data badge.

Gas category

Natural Gas - I2H

Pressure setting

G20 Natural Gas @ 20 mbar

Pressure test point

Use the oven injector

Aeration Fixed

Electrical supply

220 - 240V ~ 50Hz

Spark generator: Mains operated 6 outlet controlled by a single push button switch at the centre of the fascia to individual electrodes.

Warning: This cooker must be earthed, if mains powered.

Grill - Grill burner is surface combustion type. Spark gaps 3 - 4mm.

Hob - Burners have burner heads and caps which are removable for cleaning. Concealed electrodes to each burner.

Oven - Oven burner is sheet steel, with pierced ports in stainless steel flame strip. Spark Gap 3 - 4mm.

Flame supervision: Expansion type with fixed low rate bypass drilling in valve.

Thermostat phial: Front, centre of oven roof. *Thermostat bypass:* Screw in body stamped 73.

Appliance class

Class 1, freestanding

Countries of destination

GB - Great Britain, IE - Ireland

Gas	Burner	Nominal Rate Qn	Injector Size
Natural Gas	Grill	3.5kW	1.40
	Hob - LHF auxiliary	1.0kW	77
	Hob - LHR & RHR semi rapid	2.0kW	104
	Hob - RHF rapid	3.0kW	130
	Oven	2.5kW	180
	Total heat input	ΣQ_n 14kW	-

Notes

Notes

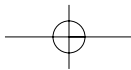
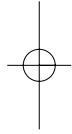
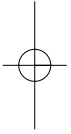

New World Customer Care

In case of difficulty within the UK and Northern Ireland,
please call our Customer Care Centre Helpline on

0151 432 7838

When you dial this number you will hear a recorded message and be given a number of options. This indicates that your call has been accepted and is being held in a queue. Calls are answered in strict rotation as our Customer Care Representatives become available.

Opening Hours for Customer Care Centre

Monday to Friday	8am - 8pm
Saturday	8.30am - 6pm
Sunday	10am - 4pm

Enter appliance numbers here for future reference:

Model No
<input type="text"/> <input type="text"/> <input type="text"/> <input type="text"/> <input type="text"/> <input type="text"/> <input type="text"/> <input type="text"/> <input type="text"/> <input type="text"/> <input type="text"/>
Serial No
<input type="text"/> <input type="text"/> <input type="text"/> <input type="text"/> <input type="text"/> <input type="text"/> <input type="text"/> <input type="text"/> <input type="text"/> <input type="text"/> <input type="text"/>

Please ensure you have the above details (Model No and Serial No) to hand when calling Customer Care. They are essential to booking your call.

Outside the UK and Northern Ireland, refer to your local supplier.

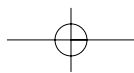
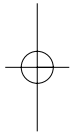
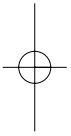



NEWWORLD

"New World" by Stoves Limited
Stoney Lane, Prescot, Merseyside L35 2XW

08 25291 00 © 2002
d